

pianerottolo  
splash r



contanot



∅ 16x180 mm



∅ 4,1 – 4,5 – 6 mm



PH 2



13 – 19 mm



◆ 3 – 4 – 5 mm



⊕ 1-2

- IT** RINGHIERA OPZIONALE
- EN** OPTIONAL RAILING
- DE** OPTIONELLE GELÄNDER
- FR** GARDE-CORPE SUPPLÉMENTAIRE
- ES** BARANDILLA SUPPLEMENTARIA
- PL** DODATKOWA PORĘCZ

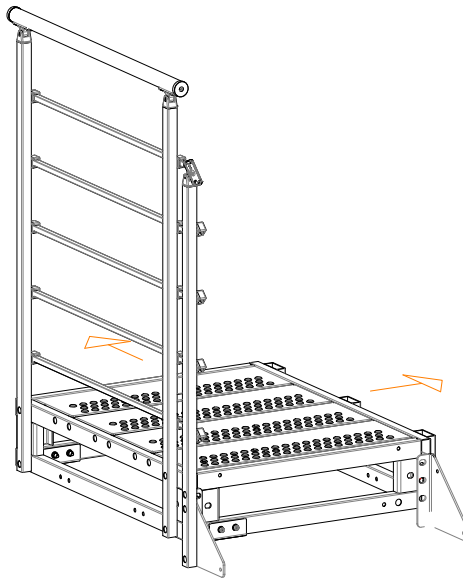
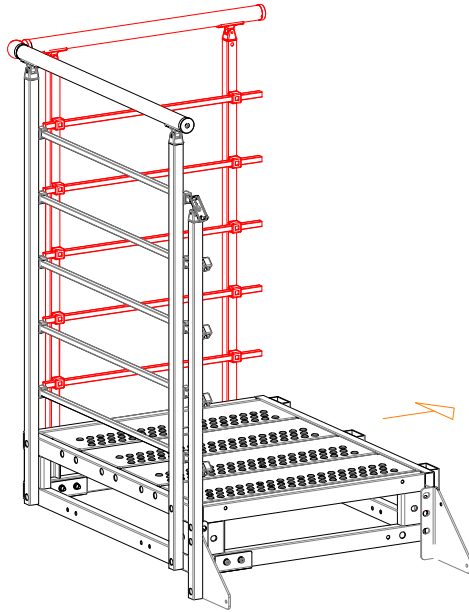

N86

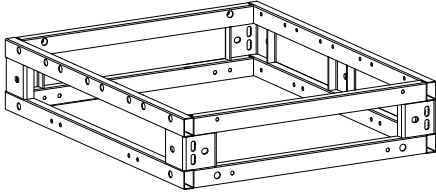

X1

L79

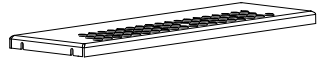

X4

N87



X2

D94



X3

CN2



X2

A75



X5

A67

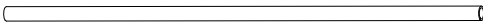

X1

A43



X2

A44



X2

A76



X10

B22



X18

B23



X27

B27



X54

B36



X2

B37



X2

BB1



X11

BB2



X13

BF4



X2

BT3



X2

BU0



X2

BU5



M8X20

X13

BU8

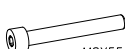

M8X55

X10

BU9



M8X45

X4

BV1



X8

BV2



X10

BV5



X9

C13



X10

C31



X10

CF5



X2

CF6



X2

D93



X10

F55



X2

H15



12,37X2,62

X10

H16



5,28X1,78

X2















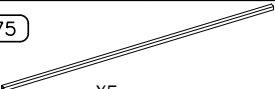













H17



3,68X1,78

X8

- IT** RINGHIERA OPZIONALE  
**EN** OPTIONAL RAILING  
**DE** OPTIONELLE GELÄNDER  
**FR** GARDE-CORPE SUPPLÉMENTAIRE  
**ES** BARANDILLA SUPLEMENTARIA  
**PL** DODATKOWA PORĘCZ

<b>CN2</b>  X2		<b>BG2</b>  X1	<b>BG3</b>  X1				
<b>A67</b>  X1		<b>A75</b>  X5					
<b>A43</b>  X2	<b>A44</b>  X2	<b>A76</b>  X10	<b>B22</b>  X4	<b>B23</b>  X3	<b>B27</b>  X6	<b>B36</b>  X2	
<b>B37</b>  X2	<b>BB6</b>  X1	<b>BF4</b>  X2	<b>BU0</b>  X2	<b>BU5</b>  M8X20 X3	<b>BV1</b>  X8	<b>BV2</b>  X10	<b>C13</b>  X10
<b>C31</b>  X10	<b>CF5</b>  X2	<b>CF6</b>  X2	<b>D93</b>  X10	<b>F55</b>  X2	<b>H15</b>  12,37X2,62 X10	<b>H16</b>  5,28X1,78 X2	<b>H17</b>  3,68X1,78 X8

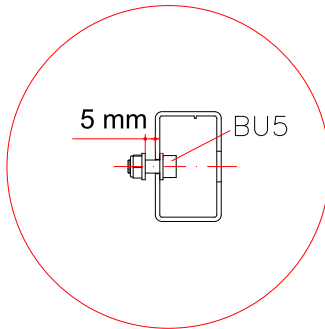
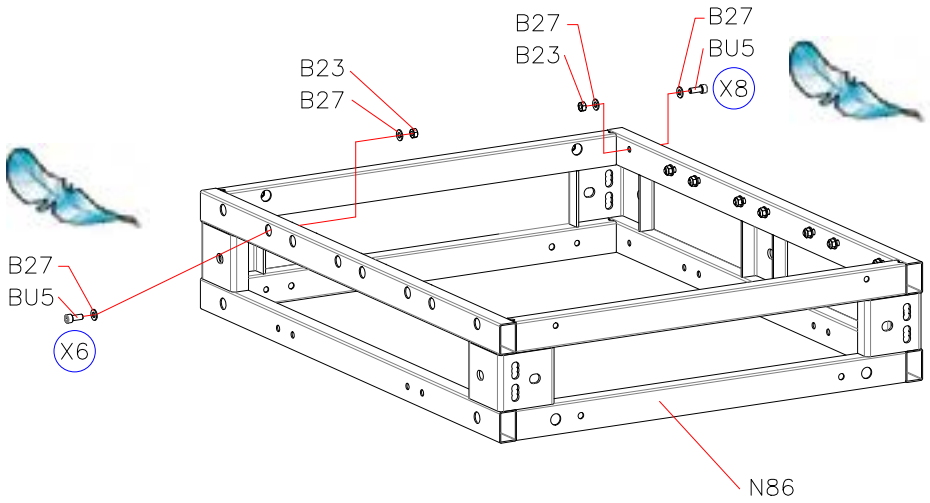

# A

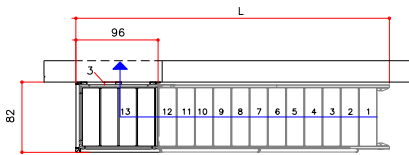
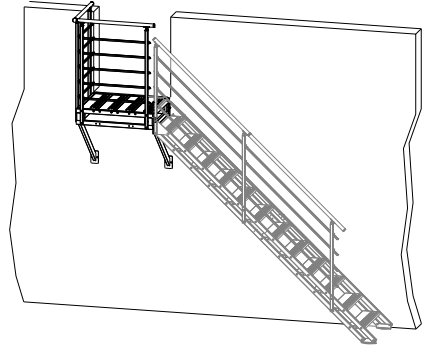
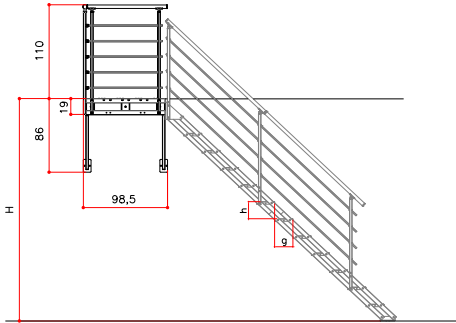

cm

H	L ≤	h ~	g ~
303+296	331	23,3	17,6
295+289	339	22,78	18,3
288+282	346	22,23	18,9
281+275	353	21,68	19,6
274+268	360	21,14	20,1
267+260	367	20,59	20,7

# B

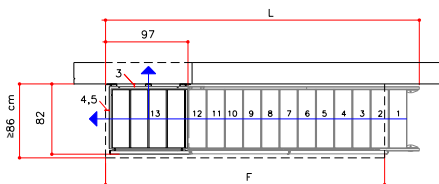
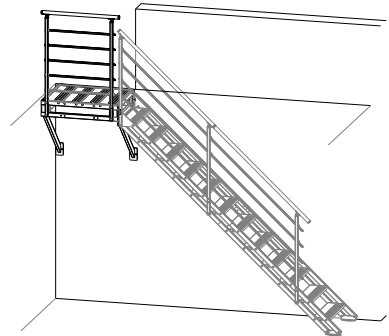
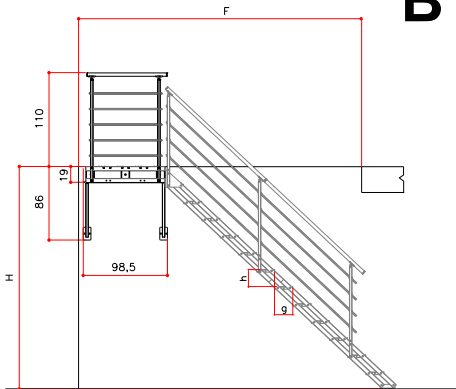

cm

H	F ≥	L ≤	h ~	g ~
303+296	278	332	23,3	17,6
295+289	285	340	22,78	18,3
288+282	291	347	22,23	18,9
281+275	317	354	21,68	19,6
274+268	322	361	21,14	20,1
267+260	329	368	20,59	20,7

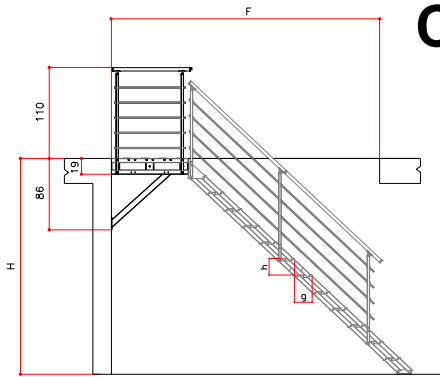

**C**

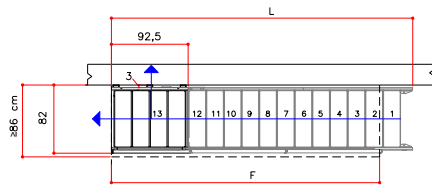
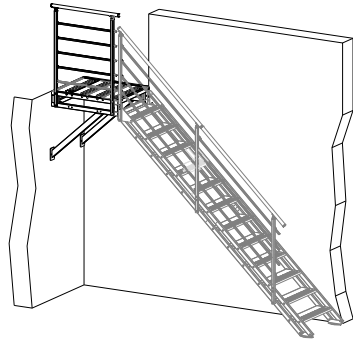

cm

H	F ≥	L ≤	h ~	g ~
303+296	273	327	23,3	17,6
295+289	280	335	22,78	18,3
288+282	286	342	22,23	18,9
281+275	312	349	21,68	19,6
274+268	317	356	21,14	20,1
267+260	324	363	20,59	20,7





# B

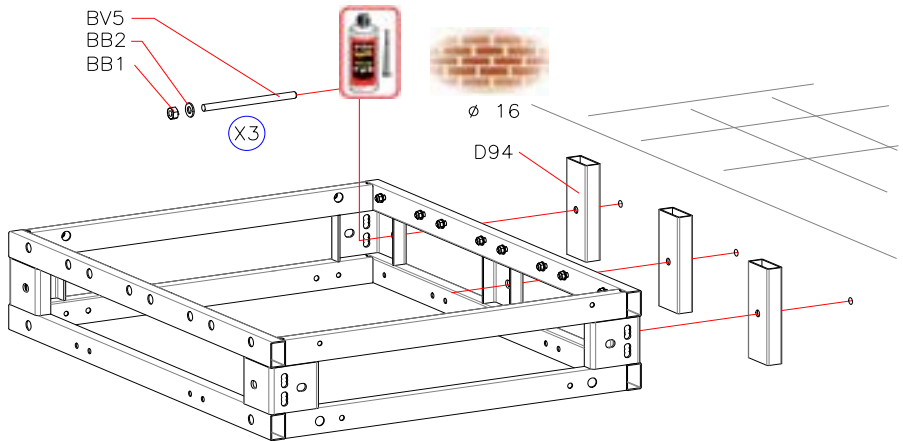
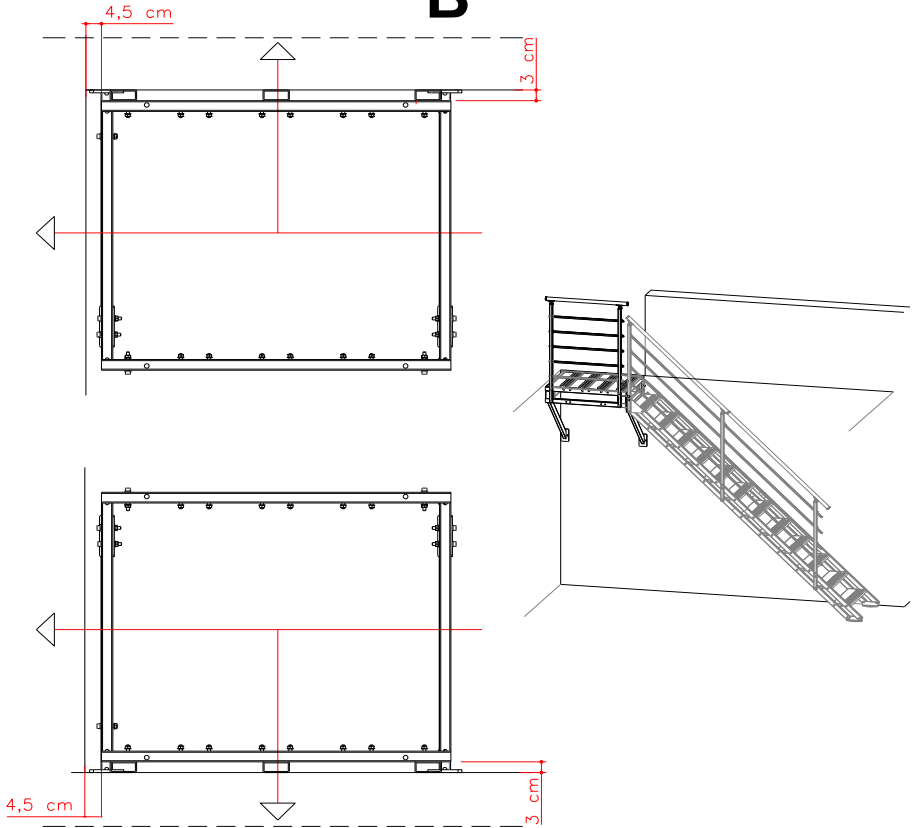

# A-B

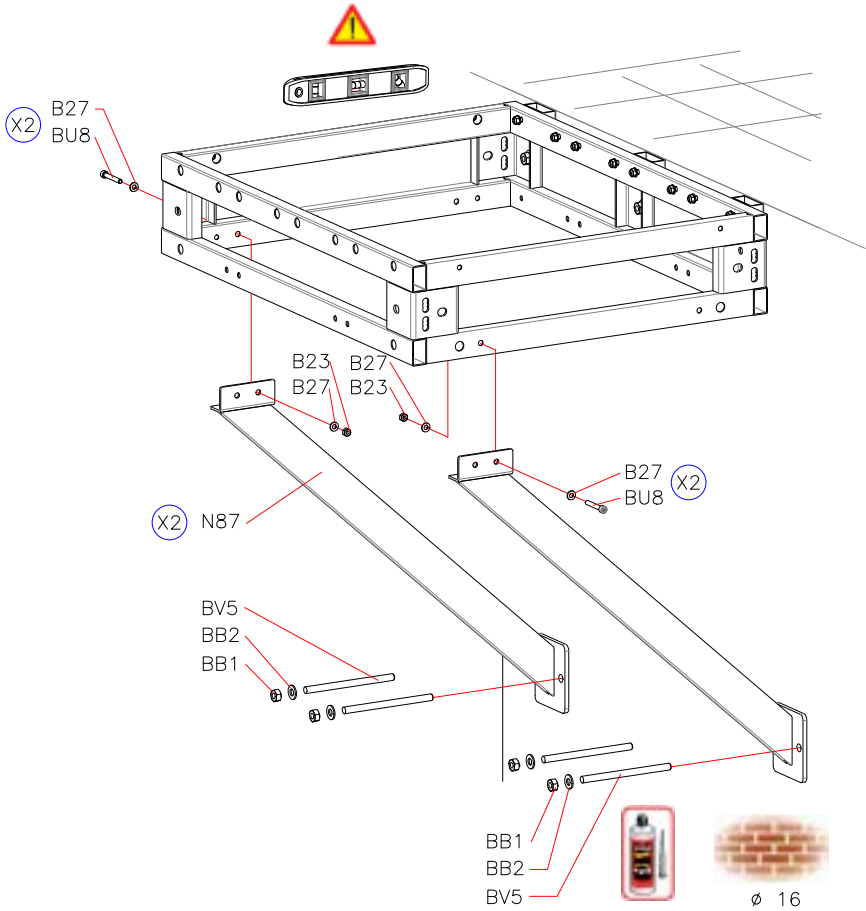



C

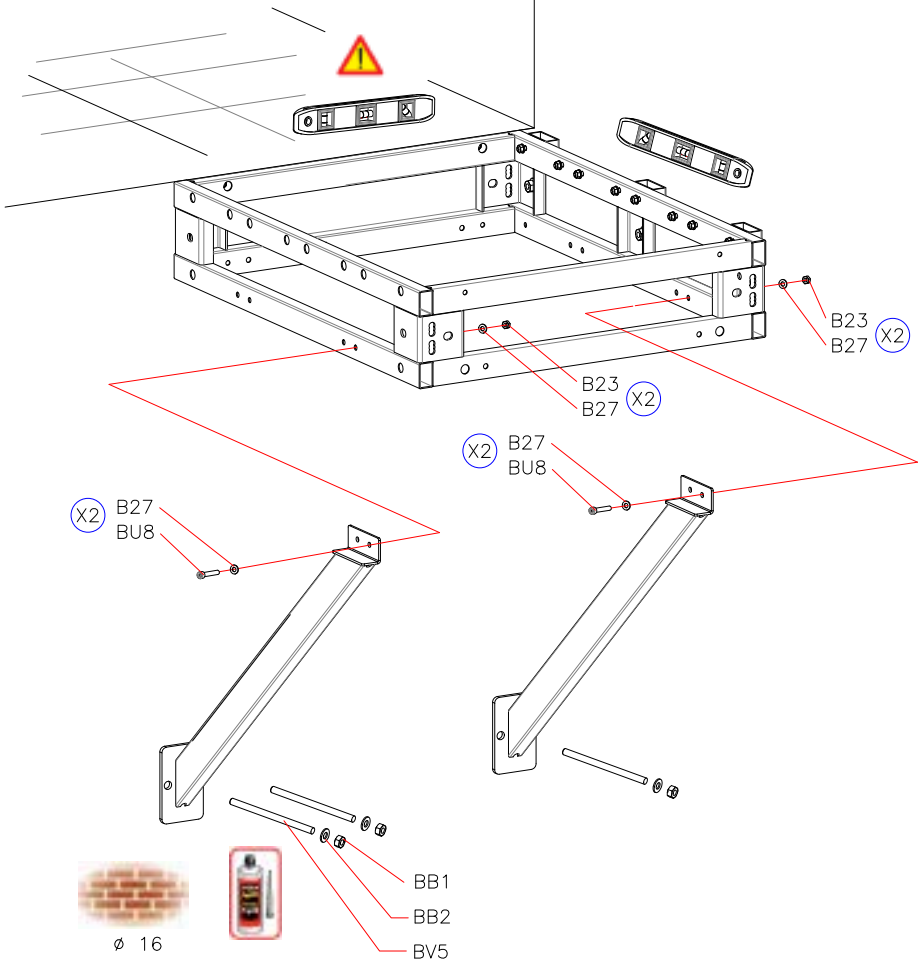

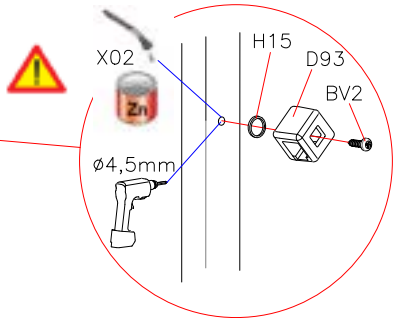
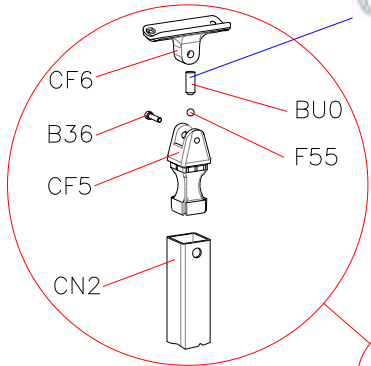

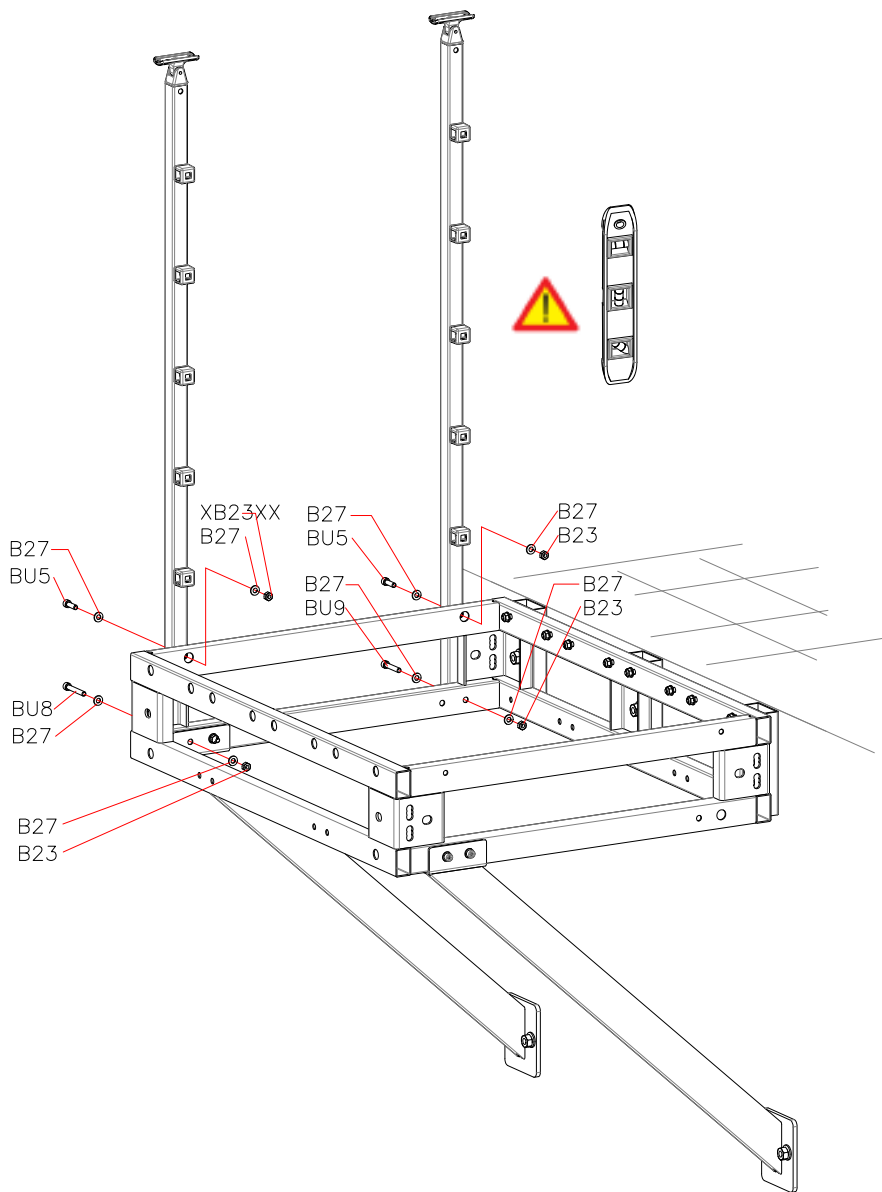

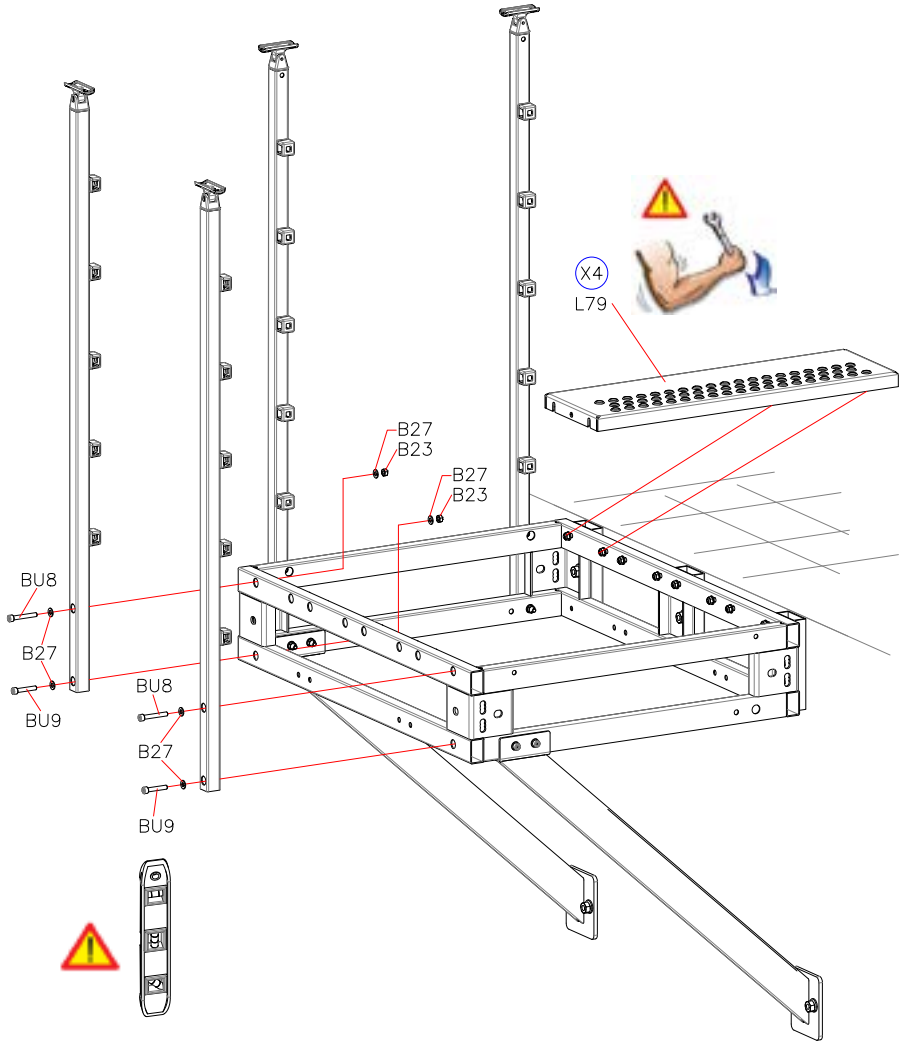



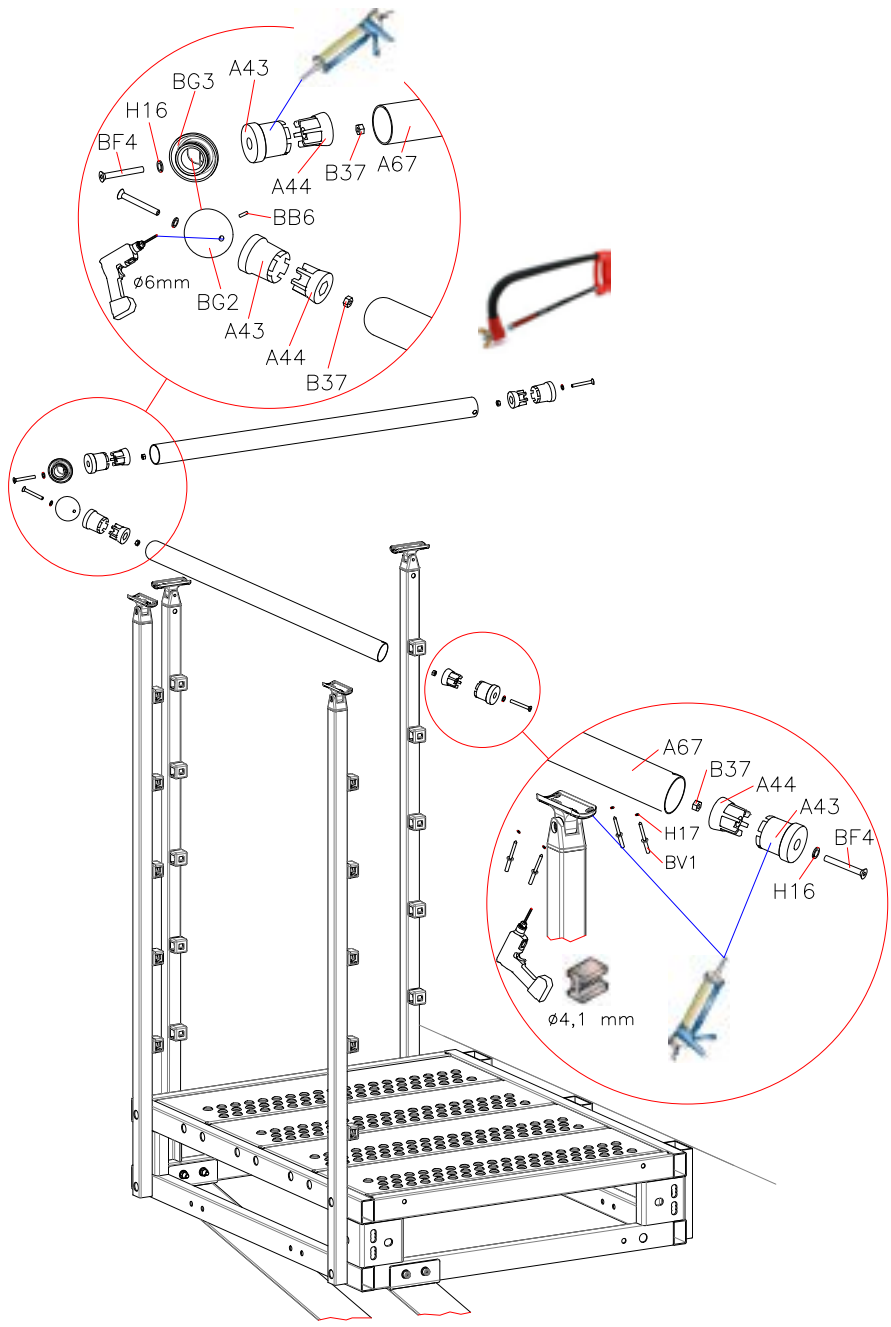

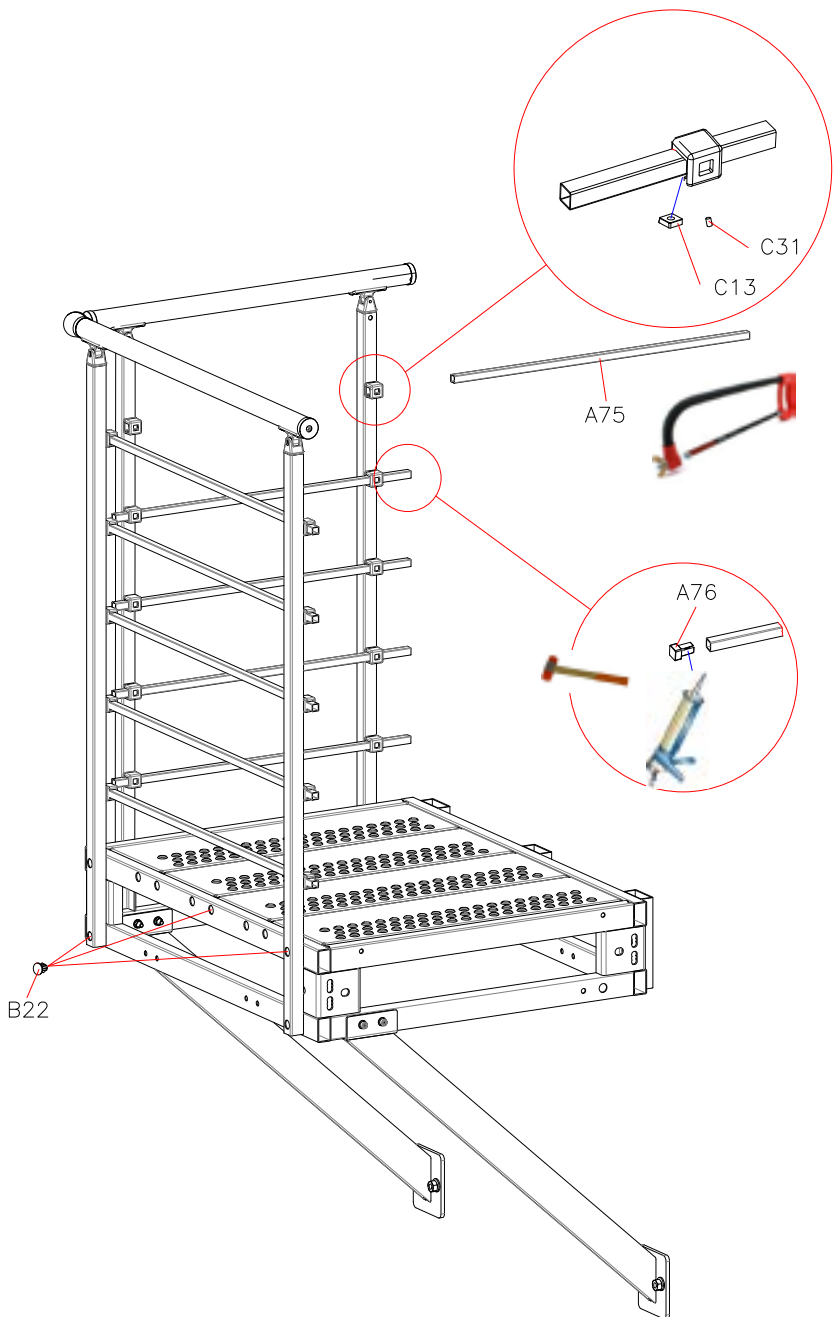

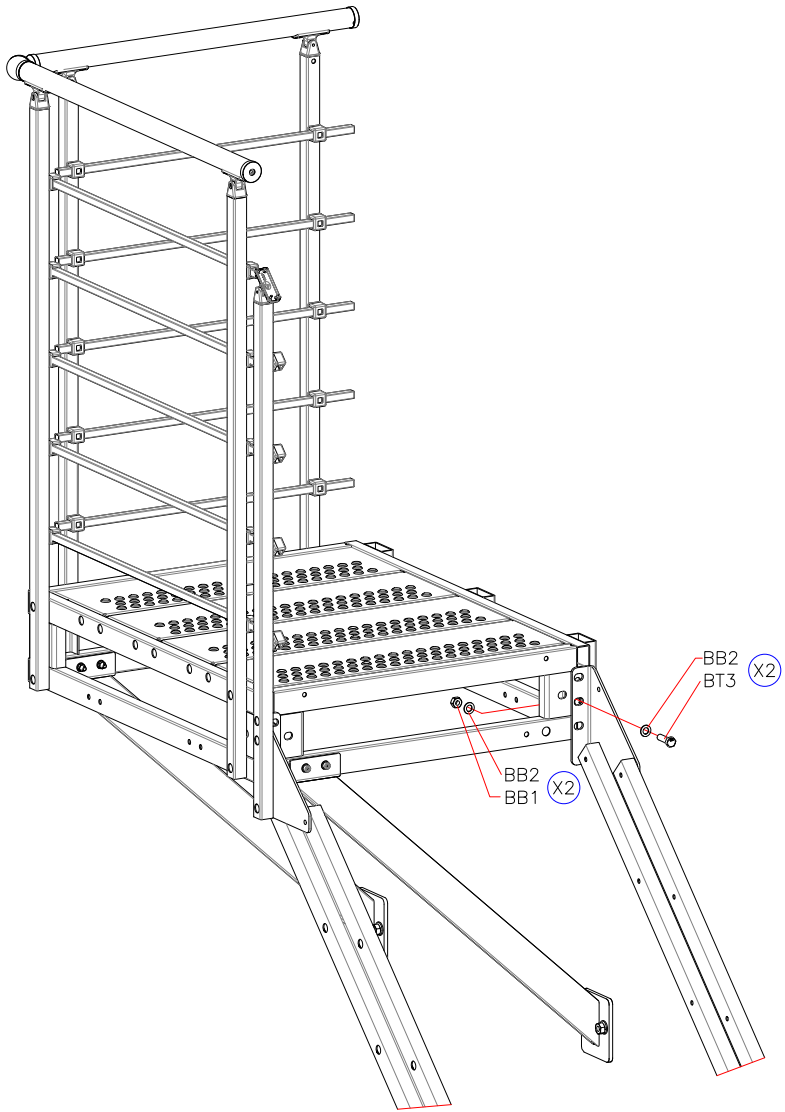





**Italiano**

**English**

**Deutsch**

**Français**

**Español**

**Polski**

DATI IDENTIFICATIVI DEL PRODOTTO

PRODUCT DETAILS

PRODUKTEIGENSCHAFTEN

DONNÉES D'IDENTIFICATION DU PRODUIT

DATOS DE IDENTIFICACIÓN

DANE IDENTYFIKACYJNE PRODUKTU

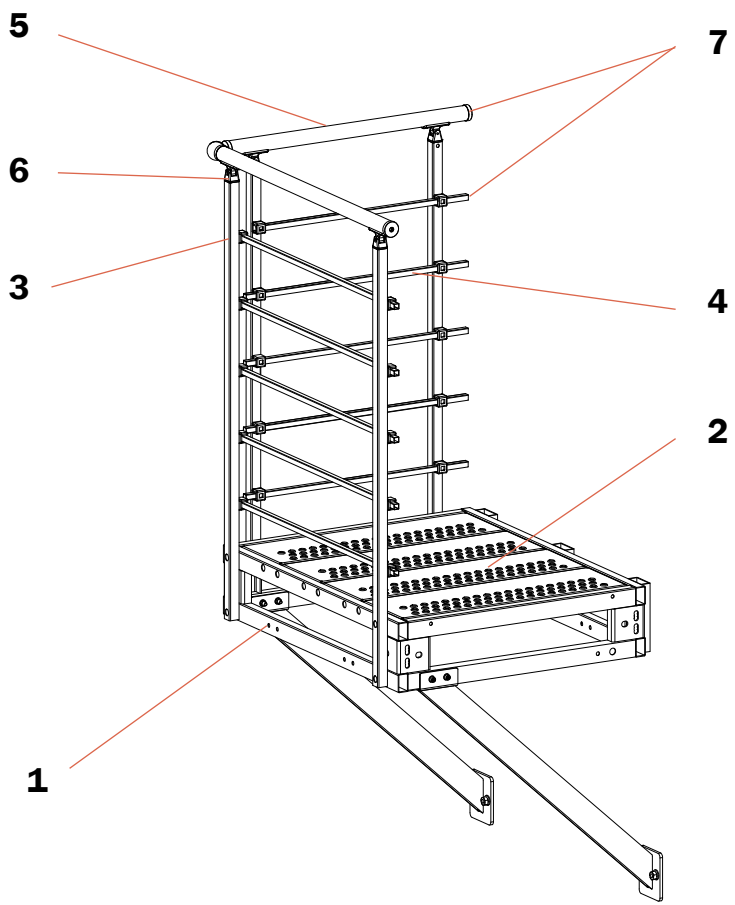

**IT)**

## **dati identificativi del prodotto**

denominaz. commerciale: **PIANEROTTOLO SPLASH R**

tipologia: pianerottolo

### **materiali impiegati**

#### **STRUTTURA**

##### **descrizione**

composta da elementi **(1)** metallici assemblati fra di loro con bulloni

##### **materiali**

Fe 360

##### **finitura**

Zincatura a caldo e verniciatura a forno con polveri poliesteri per uso esterno

#### **GRADINI**

##### **descrizione**

gradini **(2)** assemblati alla struttura con bulloni

##### **materiali**

Fe 360

##### **finitura**

Zincatura a caldo e verniciatura a forno con polveri poliesteri per uso esterno

#### **RINGHIERA**

##### **descrizione**

composta da colonnine **(3)** verticali in metallo fissate alla struttura **(1)**, da 5 tubi quadrati **(4)** e da un corrimano **(5)** in metallo

##### **materiali**

colonnine **(3)**, tubi quadrati **(4)** e corrimano **(5)**: Fe 360  
fissaggi **(6)**: zama

fissaggi **(7)**: nylon

##### **finitura**

colonnine **(3)** corrimano **(5)**: zincatura a caldo e verniciatura a forno con polveri poliesteri per uso esterno

tubi quadrati **(4)**: zincatura a caldo sendzimir e verniciatura a forno con polveri poliesteri per uso esterno

fissaggi **(6)**: fondo di cataforesi e verniciatura a forno con polveri epossidiche per uso esterno

#### **PULIZIA E MANUTENZIONE OBBLIGATORIA**

Eseguire la pulizia della scala alla prima comparsa di macchie di sporco e depositi di polvere e periodicamente almeno ogni 6 mesi con panno morbido inumidito in acqua e detersivi specifici non abrasivi ed aggressivi. NON usare mai pagliette abrasive o in ferro. Pulire ed asciugare accuratamente dopo il lavaggio con un panno in microfibra al fine di eliminare gli aloni del calcare presente nell'acqua. Dopo circa 12 mesi dalla data di installazione, controllare il serraggio della viteria dei vari componenti. Al verificarsi di qualsiasi minimo malfunzionamento è obbligatorio effettuare una manutenzione straordinaria, da eseguire subito e a regola d'arte.

#### **PRECAUZIONI D'USO**

Evitare usi impropri e non consono al prodotto. Eventuali manomissioni o installazioni non rispondenti alle istruzioni del produttore possono inficiare le conformità prestabilite del prodotto.

**EN)**

## **product identification data**

trade name: **SPLASH R LANDING**

type: landing

### **materials used**

#### **STRUCTURE**

##### **description**

composed of metallic elements **(1)** assembled between themselves by bolts

##### **materials**

Fe 360

##### **finishing**

Hot galvanized and polyester powder coating for outdoor use

#### **TREADS**

##### **description**

treads **(2)** assembled on the structure with bolts

##### **materials**

Fe 360

##### **finishing**

Hot galvanized and polyester powder coating for outdoor use

#### **RAILING**

##### **description**

composed of metal vertical balusters **(3)** fixed to the structure **(1)**, 5 square tubes **(4)** and a metal handrail **(5)**

##### **materials**

balusters **(3)**, square tubes **(4)** and handrail **(5)**: Fe 360  
fixings **(6)**: zamak

fixings **(7)**: nylon

##### **finishing**

balusters **(3)** handrail **(5)**: hot galvanized and polyester powder coating for outdoor use

square tubes **(4)**: sendzimir hot galvanized and polyester powder coating for outdoor use

fixings **(6)**: undercoat of cathaphoresis treatment and epoxy powder coated in furnace and polyester powder coating for outdoor use

#### **OBLIGATORY CLEANING AND MAINTENANCE**

Clean the treads as soon as dirt spots and dust deposits appear and at least every 6 months using a soft cloth moistened with water and specific non-abrasive and non-aggressive detergents. **NEVER** use abrasive scourers. After cleaning, thoroughly dry the surfaces with a microfibre cloth to remove the haloes that form because of the limestone in the water. Approximately 12 months from the date of installation, check tightness of the screws of the various components. Should even the smallest malfunction occur, it is obligatory to immediately and professionally carry out extraordinary maintenance.

#### **USE PRECAUTION**

Avoid any improper use that is not in accordance with the product. Possible violations or installations which don't comply with the providers instructions can invalidate the agreed product conformities.

**DE)**  
**produkteigenschaften**  
Handelsbezeichnung: **SPLASH R LANDUNG**  
Typologie: landung

## verwendete materialien

### STRUKTUR

**beschreibung**  
bestehend aus Metallteilen **(1)** die miteinander durch Bolzen verbunden sind

#### materialien

Fe 360

#### ausführung

Feuerverzinkung und Polyester-Pulverbeschichtung für Außenbereichen

### STUFEN

#### beschreibung

Stufen **(2)**, die an der Struktur mittels Bolzen befestigt sind

#### Materialien

Fe 360

#### ausführung

Feuerverzinkung und Polyester-Pulverbeschichtung für Außenbereichen

### GELÄNDER

#### beschreibung

bestehend aus senkrechten Geländerstäben **(3)** aus Metall, die mit 5 quadratischen Rohren **(4)** und einem Handlauf **(5)** aus Metall an der Struktur **(1)** befestigt sind

#### materialien

Geländerstäbe **(3)**, quadratische Rohre **(4)** und Handlauf **(5)**: Fe 360

Befestigungen **(6)**: Zamak

Befestigungen **(7)**: Nylon

#### ausführung

Geländerstäbe **(3)**, Handlauf **(5)**: Feuerverzinkung und Polyester-Pulverbeschichtung für Außenbereichen

Quadratische Rohre **(4)**: Feuerverzinkung Sendzimi und Polyester-Pulverbeschichtung für Außenbereichen

Befestigungen **(6)**: Untergrund Kataphorese und Pulverbeschichtung mit Epoxydharzen für Außenbereichen

## REINIGUNG UND VORGESCHRIEBENE INSTANDHALTUNG

Die Treppe sofort reinigen wenn Schmutzfl ecken und Staubansammlungen entstehen und sie mindestens alle 6 Monate mit einem weichen, mit Wasser und einem spezifischen, weder scheuernden, noch aggressiven Reinigungsmittel befeuchteten Lappen abzuwischen.

**NIEMALS** scheuernde Eisenschwämme verwenden. Nach der Feuchtreinigung mit einem Mikrofasertuch sorgfältig nachtrocknen, um die Schlierenbildung durch kalkhaltiges Wasser zu vermeiden. 12 Monate nach der Montage das Anzugsmoment der Schrauben der verschiedenen Komponenten kontrollieren. Bei Auftreten einer noch so geringen Funktionsstörung muss unbedingt sofort eine fachgerechte außerordentliche Instandhaltung durchgeführt werden.

## VORSICHTSMAßNAHMEN FÜR DIE ANWENDUNG

Die falsche und unangemessene Verwendung des Produkts vermeiden. Eventuelle Beschädigungen oder nicht der Montageanleitung des Herstellers gemässe Einrichtungen können die vorgegebene Produktkonformität für ungültig erklären.

**FR)**  
**données d'identification du produit**  
dénomination commerciale : **ATTERRISSAGE SPLASH R**  
typologie : atterrissage

## matériaux utilisés

### STRUCTURE

#### description

composé d'éléments **(1)** métalliques assemblés entre eux par boulonnage

#### matériau

Fe 360

#### finition

Galvanisation à chaud et peinture en poudre polyester pour extérieur

### MARCHES

#### description

marches **(2)** assemblées à la structure par boulonnage

#### matériau

Fe 360

#### finition

Galvanisation à chaud et peinture en poudre polyester pour extérieur

### GARDE-CORPS

#### description

composé de colonnettes verticales **(3)** en métal fixées à la structure **(1)**, de 5 tubes carrés **(4)** et d'une main courante **(5)** en métal

#### matériau

colonnettes **(3)**, tubes carrés **(4)** et main courante **(5)**:

Fe 360

fixations **(6)** : zamak

fixations **(7)** : nylon

#### finition

colonnettes **(3)**, main courante **(5)** : galvanisation à chaud et peinture en poudre polyester pour extérieur

tubes carrés **(4)** : galvanisation à chaud sendzimir et peinture en poudre polyester pour extérieur

fixations **(6)** : couche de fond par cathaphorèse et thermolaquage avec poudres époxy pour extérieur

## NETTOYAGE ET MAINTENANCE OBLIGATOIRE

Nettoyer les marches dès que des taches de saleté ou des dépôts de poussière apparaissent ; effectuer également un nettoyage périodique, tous les 6 mois, à l'aide d'un chiffon doux, humidifié d'eau et de détergents spécifiques non abrasifs et non agressifs. **NE JAMAIS** utiliser de la paille de fer abrasive. Après lavage, nettoyer et essuyer soigneusement avec un chiffon en microfibre, afin d'éliminer les auréoles provoquées par le calcaire contenu dans l'eau. Environ 12 mois après la date d'installation, contrôler le serrage des vis des différents composants. À la moindre défaillance, il est obligatoire d'effectuer immédiatement une maintenance corrective, dans les règles de l'art.

## PRECAUTION D'UTILISATION

Eviter l'utilisation impropre et non conforme au produit. D'éventuelles alterations ou installations non correspondantes aux instructions du producteur peuvent invalider les conformités préétablies du produit.



**ES)**

## **datos de identificación del producto**

denominación comercial: **ATERRIZAJE SPLASH R**

tipo: aterrizaje

### **materiales empleados**

#### **ESTRUCTURA**

##### **descripción**

compuesta por elementos **(1)** metálicos ensamblados unos con otros mediante pernos.

##### **materiales**

Fe 360

##### **acabado**

Galvanización en caliente y barnizado con polvo de poliéster para exterior

#### **PELDAÑOS**

##### **descripción**

peldaños **(2)** ensamblados a la estructura mediante pernos

##### **materiales**

Fe 360

##### **acabado**

Galvanización en caliente y barnizado con polvo de poliéster para exterior

#### **BARANDILLA**

##### **descripción**

compuesta por barrotes **(3)** verticales de metal fijados a la estructura **(1)**, 5 tubos de sección cuadrada **(4)** y un pasamanos **(5)** de metal

##### **materiales**

barrotes **(3)**, tubos de sección cuadrada **(4)** y

pasamanos **(5)**: Fe 360

fijaciones **(6)**: zamac

fijaciones **(7)**: nylon

##### **acabado**

barrotes **(3)** pasamanos **(5)**: galvanización en caliente y barnizado con polvo de poliéster para exterior

tubos de sección cuadrada **(4)**: galvanización en caliente sendzimir y barnizado con polvo de poliéster para exterior

fijaciones: **(6)**: fondo de cataforesis y barnizado en horno con polvos epoxídicos para exterior

#### **LIMPIEZA Y MANTENIMIENTO OBLIGATORIO**

Realizar la limpieza de la escalera en cuanto aparezcan manchas de suciedad y depósitos de polvo, y periódicamente al menos cada 6 meses, con un paño suave humedecido en agua y detergentes específicos no abrasivos ni agresivos. **NO** utilizar nunca lanas abrasivas o de hierro. Limpiar y secar bien después del lavado utilizando un paño de microfibra para eliminar las aureolas de cal dejadas por el agua. Transcurridos unos 12 meses desde la fecha de instalación, comprobar que los tornillos que fijan las distintas partes sigan bien apretados. Ante el menor defecto de funcionamiento, es obligatorio realizar un mantenimiento extraordinario según las reglas del arte.

#### **PRECAUCIONES DE USO**

Evitar usos impropios y no conformes con el producto. Eventuales manipulaciones o instalaciones que no cumplan con las instrucciones del fabricante pueden menoscabar las cualidades certificadas en las pruebas de conformidad a las que previamente fue sometido el producto.







# PIAN. SPLASH R

D.U.M.  
03/2021

Fontanot S.p.A.  
**Sede legale ed amministrativa**  
via P Paolo Pasolini, 6  
47853 Cerasolo Ausa  
Rimini, Italy

tel. +39.0541.90.61.11  
fax. +39.0541.90.61.24  
info@fontanot.it  
www.fontanot.it

cod. 069016001

Design: Centro Ricerche Fontanot

Sistema aziendale Fontanot S.p.A.  
certificato CSQ ISO-9001

